

Feasibility Analysis of the Positioning of Superconducting Fault Current Limiters for the Smart Grid Application Using Simulink and SimPowerSystem

Umer A. Khan, J. K. Seong, S. H. Lee, S. H. Lim, and B. W. Lee, *Member, IEEE*

Abstract—One of the most important topics regarding the application of superconducting fault current limiters (SFCL) for upcoming smart grid is related to its possible effect on the reduction of abnormal fault current and the suitable location in the micro grids. Due to the grid connection of the micro grids with the current power grids, excessive fault current is a serious problem to be solved for successful implementation of micro grids. However, a shortage of research concerning the location of SFCL in micro grid is felt. In this work, a resistive type SFCL model was implemented by integrating Simulink and SimPowerSystem blocks in Matlab. The designed SFCL model could be easily utilized for determining an impedance level of SFCL according to the fault-current-limitation requirements of various kinds of the smart grid system. In addition, typical smart grid model including generation, transmission and distribution network with dispersed energy resource was modeled to determine the location and the performance of the SFCL. As for a dispersed energy resource, 10 MVA wind farm was considered for the simulation. Three phase faults have been simulated at different locations in smart grid and the effect of the SFCL and its location on the wind farm fault current was evaluated. Consequently, the optimum arrangement of the SFCL location in Smart Grid with renewable resources has been proposed and its remarkable performance has been suggested.

Index Terms—Fault current, micro grid, smart grid, superconducting fault current limiter, wind farm.

I. INTRODUCTION

CONVENTIONAL protection devices installed for protection of excessive fault current in electric power systems, especially at the high voltage substation level, are the circuit breakers tripped by over-current protection relay which has a response-time delay that allows initial two or three fault current cycles to pass through before getting activated [1].

Manuscript received August 02, 2010; accepted October 18, 2010. Date of publication December 03, 2010; date of current version May 27, 2011. This work was supported by the research fund of Hanyang University (HY-2010-N). Gratitude is expressed to Higher Education Commission Government of Pakistan for sponsoring the studies of Mr. Umer Amir Khan.

U. A. Khan, J. K. Seong, and S. H. Lee are with the Department of Electronics, Electrical, Control & Instrumentation Engineering of Hanyang University, Ansan 426-791, Korea.

S. H. Lim is with the School of Electrical Engineering, Soongsil University, (156-743)511 Sangdo-Dong, Dongjak-Gu, Seoul, Korea.

B. W. Lee is with the School of Electrical Engineering & Computer Science, Hanyang University, Ansan 426-791, Korea (e-mail: bangwook@hanyang.ac.kr).

Color versions of one or more of the figures in this paper are available online at <http://ieeexplore.ieee.org>.

Digital Object Identifier 10.1109/TASC.2010.2089591

But, superconducting fault current limiter (SFCL) is innovative electric equipment which has the capability to reduce fault current level within the first cycle of fault current [2]. The first-cycle suppression of fault current by a SFCL results in an increased transient stability of the power system carrying higher power with greater stability [3].

Smart grid is the novel term used for future power grid which integrates the modern communication technology and renewable energy resources for the 21st century power grid in order to supply electric power which is cleaner, reliable, resilient and responsive than conventional power system [4].

One of the key elements of the smart grid is decentralization of the power grid network into smaller grids, which are known as micro grids, having distributed generation sources (DG) connected with them. These micro grids may or may not be connected with conventional power grid, but the need to integrate various kinds of DGs and loads with safety should be satisfied [2]. However, newly emerging problems due to these integrations are also of severe nature and needs to be taken care of. Two major challenges expected by direct connection of DGs with the power grid are the excessive increase in fault current and the islanding issue which is caused when, despite a fault in the power grid, DG keeps on providing power to fault-state network [5].

Up to now, there were some research activities discussing the fault current issues of smart grid [6], [7]. But the applicability of a SFCL into micro grid was not found yet. Hence, solving the problem of increasing fault current in micro grids by using SFCL technology is the main concern of this work. In this paper, the effect of SFCL and its position was investigated considering a wind farm integrated with a distribution grid model as one of typical configurations of the smart grid. The impacts of SFCL on the wind farm and the strategic location of SFCL in a micro grid which limits fault current from all power sources and has no negative effect on the integrated wind farm was suggested.

II. SIMULATION SET-UP

Matlab/Simulink/SimPowerSystem was selected to design and implement the SFCL model. A complete smart grid power network including generation, transmission, and distribution with an integrated wind farm model was also implemented in it. Simulink/SimPowerSystem has number of advantages over its contemporary simulation software (like EMTP, PSPICE) due to its open architecture, a powerful graphical user interface and versatile analysis and graphics tools. Control systems designed

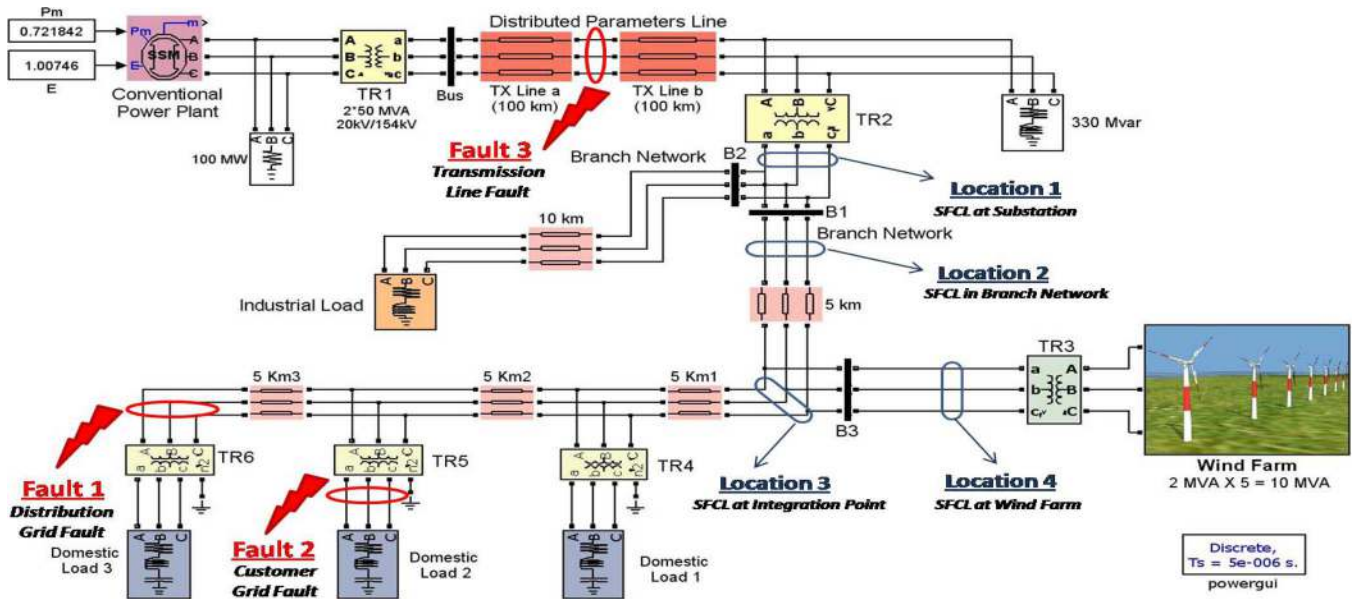

Fig. 1. Power system model designed in Simulink/SimPowerSystem. Fault and SFCL locations are indicated in the diagram.

in Simulink can be directly integrated with SimPowerSystem models [8].

A. Power System Model

The modeled power system was based on Korean electric transmission and distribution power system. Newly developed micro grid model was designed by integrating a 10 MVA wind farm with the distribution network. Fig. 1 shows the power system model designed in Simulink/SimPowerSystem.

The power system is composed of a 100 MVA conventional power plant, composed of 3-phase synchronous machine, connected with 200 km long 154 kV distributed-parameters transmission line through a step-up transformer TR1. At the substation (TR2), voltage is stepped down to 22.9 kV from 154 kV. High power industrial load (6 MW) and low power domestic loads (1 MW each) are being supplied by separate distribution branch networks. The wind farm is directly connected with the branch network (B1) through transformer TR3 and is providing power to the domestic loads. The 10 MVA wind farm is composed of five fixed-speed induction-type wind turbines each having a rating of 2 MVA. At the time of fault, the domestic load is being provided with 3 MVA out of which 2.7 MVA is being provided by the wind farm.

In Fig. 1 artificial fault and locations of SFCL are indicated in the diagram. Three kinds of fault points are marked as Fault 1, Fault 2 and Fault 3, which represent three-phase-to-ground faults in distribution grid, customer grid and transmission line respectively.

Four prospective locations for SFCL installation are marked as Location 1 (Substation), Location 2 (Branch Network), Locations 3 (Wind farm integration point with the grid) and Location 4 (Wind Farm). Generally, conventional fault current protection devices are located in Location 1 and Location 2.

The output current of wind farm (the output of TR3 in Fig. 1) for various SFCL locations have been measured and analysed in

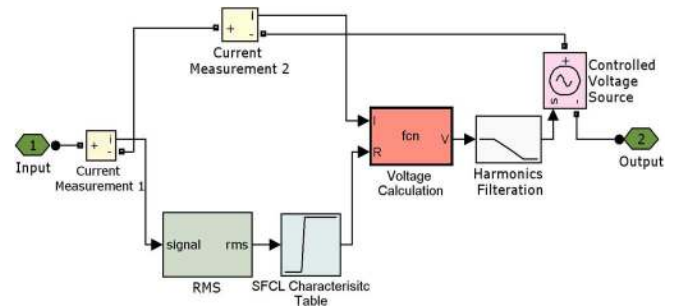

Fig. 2. Single phase SFCL model developed in Simulink/Simpowersystem.

Section III for determining the optimum location of SFCL in a micro grid.

B. Resistive SFCL Model

The three phase resistive type SFCL was modeled considering four fundamental parameters of a resistive type SFCL [9]. These parameters and their selected values are: 1) transition or response time = 2 msec, 2) minimum impedance = 0.01 Ohms and maximum impedance = 20 Ohms, 3) triggering current = 550 A and 4) recovery time = 10 msec. Its working voltage is 22.9 kV.

Fig. 2 shows the SFCL model developed in Simulink/SimPowerSystem. The SFCL model works as follows. First, SFCL model calculates the RMS value of the passing current and then compares it with the characteristic table. Second, if a passing current is larger than the triggering current level, SFCL's resistance increases to maximum impedance level in a pre-defined response time. Finally, when the current level falls below the triggering current level the system waits until the recovery time and then goes into normal state.

Fig. 3 shows the result of verification test of SFCL model conducted on power network model depicted in Fig. 1. SFCL

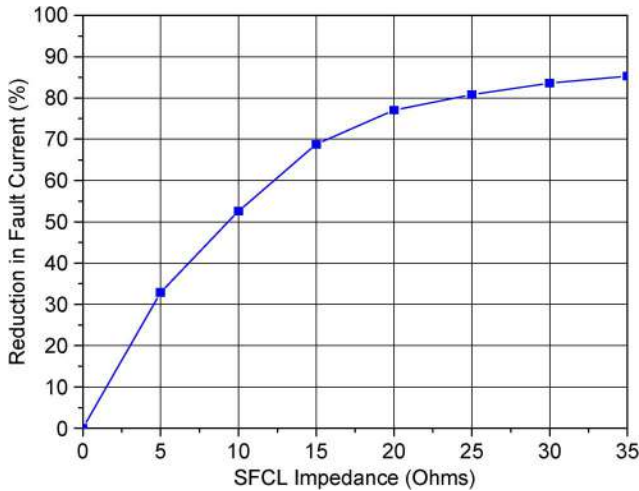

Fig. 3. SFCL performance evaluation graph indicating the relationship between SFCL impedance and reduction in fault current.

has been located at substation (Location 1) and for a distribution grid fault (Fault 1), various SFCL impedance values versus its fault current reduction operation has been plotted. Maximum fault current (No SFCL case) is 7500 A at 22.9 kV for this arrangement.

III. RESULTS AND DISCUSSION

Four scenarios of SFCL's possible locations were analysed for three different fault occurring points in the power system depicted in Fig. 1. First, we assumed that single SFCL was located at Location 1 (Substation). Second, single SFCL was located at Location 2 (Branch Network). Third, single SFCL was located at Location 3 (Wind farm integration point with the grid).

Finally, in order to clarify the usefulness of dual SFCL installed together for different locations, SFCLs were located at Location 1 (Substation) and Location 4 (Wind Farm) respectively.

A. Fault in the Distribution Grid (Fault 1)

Fig. 4 shows a comparison between fault current from the wind farm (measured at output of TR3 in Fig. 1) for different SFCL locations in the case when a three-phase-to-ground fault was initiated in the distribution grid (Fault 1 in Fig. 1).

In the case of SFCL located at Location 1 (Substation) or Location 2 (Branch Network), fault current contribution from the wind farm was increased and the magnitude of fault current is higher than 'No FCL' situation. These critical observations imply that the installation of SFCL in Location 1 and Location 2, instead of reducing, has increased the DG fault current. This sudden increase of fault current from the wind farm is caused by the abrupt change of power system's impedance. The SFCL at these locations (Location 1 or Location 2) entered into current limiting mode and reduced fault current coming from the conventional power plant due to rapid increase in its resistance. Therefore, wind farm which is the other power source and also closer to the Fault 1 is now forced to supply larger fault current to fault point (Fault 1).

In the case when SFCL is installed at the integration point of wind farm with the grid, marked as Location 3 in Fig. 1, the

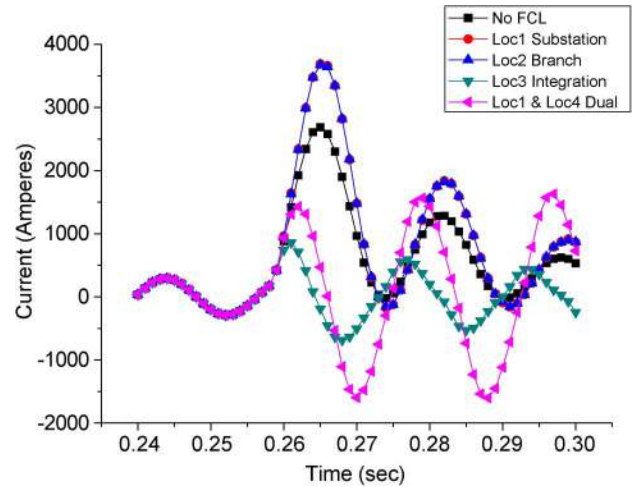

Fig. 4. Comparison of the wind farm fault currents for four SFCL locations in case of fault in distribution grid (Fault 1).

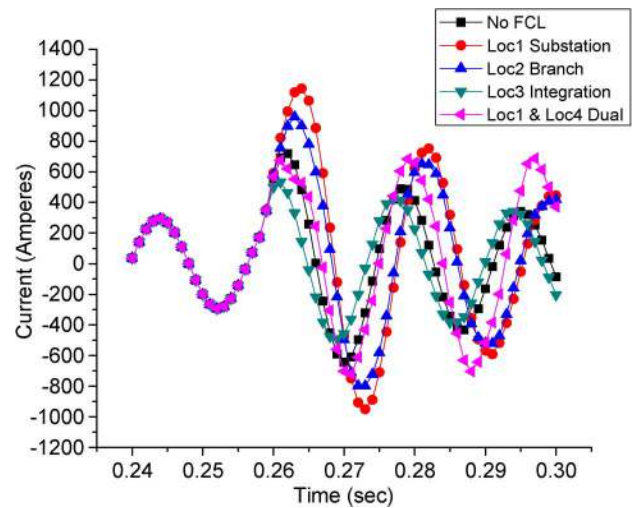

Fig. 5. Comparison of the wind farm fault currents for four SFCL locations in case of fault in customer grid (Fault 2).

wind farm fault current has been successfully reduced. SFCL gives 68% reduction of fault current from wind farm and also reduce the fault current coming from conventional power plant because SFCL is located in the direct path of any fault current flowing towards Fault 1.

With dual SFCL installed at Location 1 and Location 4, 45% reduction in fault current is also observed. However, even though two SFCLs were installed, wind farm fault current reduction is lower than what was achieved by the single SFCL installed at Location 3. From the simulation results, it was known that the installation of two SFCLs (Location 1 and Location 4) is economically and technically not feasible.

B. Fault in Customer Grid (Fault 2)

Fig. 5 shows a comparison between fault current from the wind farm (measured at output of TR3 in Fig. 1) for different SFCL locations in the case when a three-phase-to-ground fault was initiated in the customer grid (Fault 2 in Fig. 1).

Fault 2 is comparatively a small fault as it occurred in low voltage customer side distribution network. The results obtained

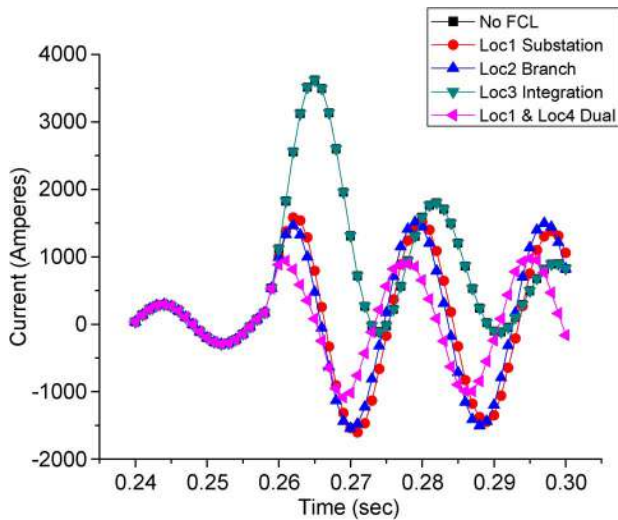

Fig. 6. Comparison of the wind farm fault currents for four SFCL locations in case of fault in transmission line (Fault 3).

are similar to what were observed in the case of distribution grid (Fault 1) as explained in Section III-A.

Once again the best results are obtained when a single SFCL is located at Location 3, which is the integration point of the wind farm with the distribution grid.

C. Fault in Transmission Line (F3)

Fault 3 in Fig. 1 indicates the rarely occurring transmission line fault which results in very large fault currents. Fig. 6 shows a comparison between fault current from the wind farm (measured at output of TR3 in Fig. 1) for different SFCL locations in the case when a three-phase-to-ground fault was initiated in the transmission line (Fault 3 in Fig. 1).

When a fault in transmission line occurs, fault current from the conventional power plant as well as the wind farm would flow towards fault point. In case of wind farm, fault current would flow in reverse direction through the substation and into the transmission line to fault point. Thus, on the contrary to the previous results obtained in Sections III-A and III-B, SFCL positioned at Location 1 (Substation) or Location 2 (Branch Network) reduces the wind farm fault current. This result comes from the fact that SFCL is installed directly in the path of reverse current being generated by the wind farm towards fault point.

The majority of faults in a power system might occur in the distribution grid and the SFCL designed to protect micro-grid should not be expected to cater for the transmission line faults (Fault 3). An important aspect to be noted here is that wind farms on distribution side can contribute fault currents to transmission line faults and this phenomenon must be considered while designing the protection schemes for the smart grid. Fig. 7 shows the comparison between four SFCL installation scenarios and their contribution in wind farm fault current reduction for distribution grid faults (Fault 1 and Fault 2). When the SFCL was strategically located at the point of integration of the wind farm with the grid (Location 3), the highest fault current reduction was achieved. The performance of SFCL at this location was even better than dual SFCL located at Location 1 and Loca-

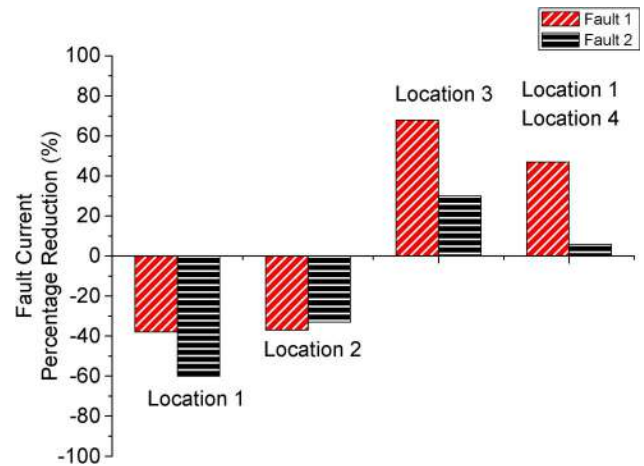

Fig. 7. Comparison of the reduction in wind farm fault current for four SFCL installation scenarios.

TABLE I
PERCENTAGE CHANGE IN WIND FARM FAULT CURRENT DUE TO SFCL LOCATIONS

SFCL Location	Fault 1 Distribution Grid		Fault 2 Customer Grid		Fault 3 Transmission Line	
	%	Affect	%	Affect	%	Affect
Location 1	38%	Increased	60%	Increased	57%	Decreased
Location 2	37%	Increased	33%	Increased	60%	Decreased
Location 3	68%	Decreased	30%	Decreased	0%	-
Location 1 and Location 4	47%	Decreased	6%	Decreased	72%	Decreased

tion 4 at a time. Thus, multiple SFCLs in a micro grid are not only costly but also less efficient than strategically located single SFCL. Moreover, at Location 3, fault current coming from the conventional power plant was also successfully limited. Reduction in wind farm fault current for various SFCL locations were summarized in Table I.

IV. CONCLUSION

This paper presented a feasibility analysis of positioning of the SFCL in rapidly changing modern power grid. A complete power system along with a micro grid (having a wind farm connected with the grid) was modeled and transient analysis for three-phase-to-ground faults at different locations of the grid were performed with SFCL installed at key locations of the grid. It has been observed that SFCL should not be installed directly at the substation or the branch network feeder. This placement of SFCL results in abnormal fault current contribution from the wind farm. Also multiple SFCLs in micro grid are inefficient both in performance and cost. The strategic location of SFCL in a power grid which limits all fault currents and has no negative effect on the DG source is the point of integration of the wind farm with the power grid.

REFERENCES

- [1] S. Sugimoto, J. Kida, H. Arita, C. Fakuji, and T. Yamagiwa, "Principle and characteristics of a fault current limiter with series compensation," *IEEE Trans. Power Delivery*, vol. 11, no. 2, pp. 842–847, Apr. 1996.

- [2] T. Jamasb, W. J. Nuttall, and M. G. Pollitt, *Future Electricity Technologies and Systems*. Cambridge: Cambridge Univ. Press, 2006, pp. 83–97, 235–246.
- [3] B. C. Sung, D. K. Park, J. W. Park, and T. K. Ko, “Study on a series resistive SFCL to improve power system transient stability: Modeling, simulation and experimental verification,” *IEEE Trans. Industrial Electron.*, vol. 56, no. 7, pp. 2412–2419, Jul. 2009.
- [4] Litos Strategic Communication, “The Smart Grid: An Introduction,” 2008 [Online]. Available: <http://www.oe.energy.gov/SmartGridIntroduction.htm>, Prepared for U.S. Department of Energy.
- [5] R. Strzelecki and G. Benysek, *Power Electronics in Smart Electrical Energy Networks*. London, U.K.: Springer-Verlag London Ltd., 2008, pp. 203–213.
- [6] J. Driesen, P. Vermeyen, and R. Belmans, “Protection issues in micro-grids with multiple distributed generation units,” in *Power Conversion Conf.*, Nagoya, April 2007, pp. 646–653.
- [7] W. Friedl, L. Fickert, E. Schmautzer, and C. Obkircher, “Safety and reliability for smart-, micro-, and islanded grids,” presented at the CIREN Seminar: SmartGrids for Distribution, Jun. 2008, Paper 107.
- [8] L. Dessaint, K. Al-Haddad, H. Le-Huy, G. Sybille, and P. Brunelle, “A power system tool based on simulink,” *IEEE Trans. Industrial Electron.*, vol. 46, no. 6, pp. 1252–1254, Dec. 1999.
- [9] K. Maki, S. Repo, and P. Jarventausta, “Effect of wind power based distributed generation on protection of distribution network,” in *IEEE Developments in Power System Protection*, Dec. 2004, vol. 1, pp. 327–330.